

Camper para coche

GARBÍ

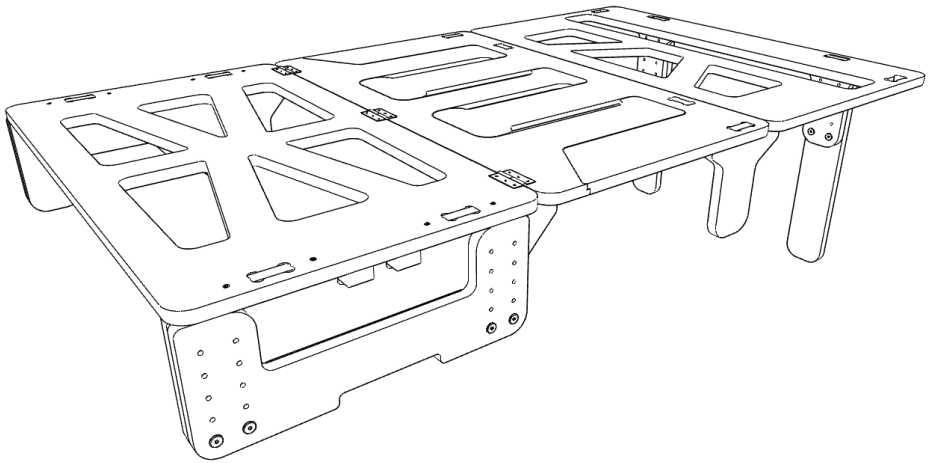

Fabricado y diseñado en Valencia.

Despiece

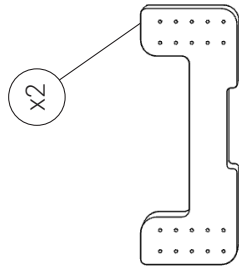

x2

AA-PDP1
AA-PIP1

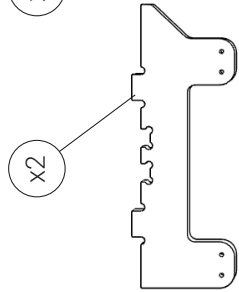

x2

AA-PDP2
AA-PIP2

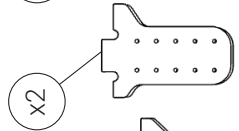

x2

AA-PDF1
AA-PIF1

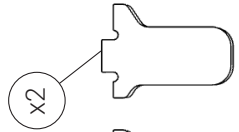

x2

AA-PDM
AA-PIM

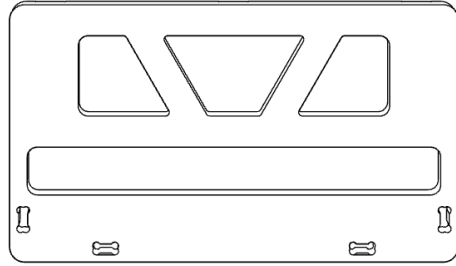

AA-CF

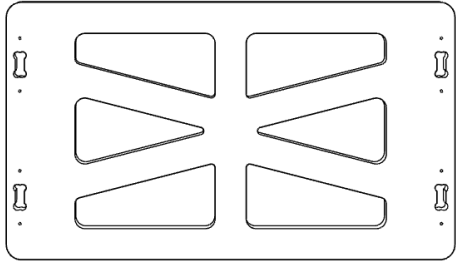

AA-CP

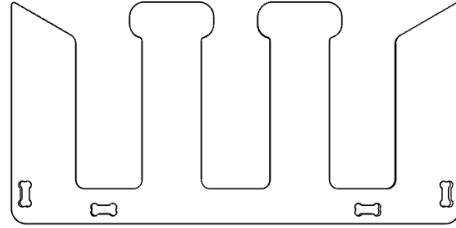

AA-L2

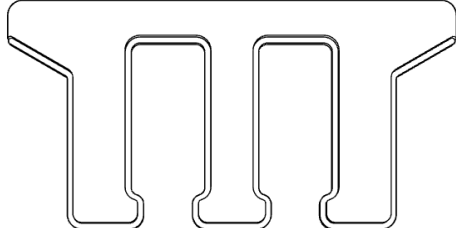

AA-L1



AA-SP



AA-SOPM

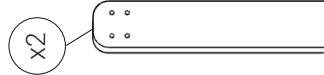

x2

AA-PDF2
AA-PIF2

Despiece

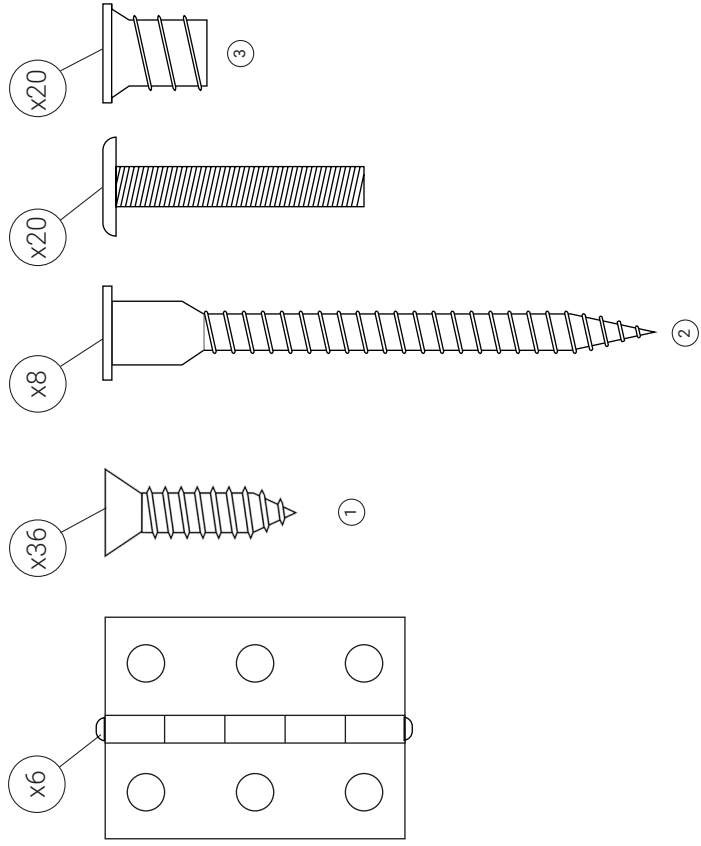

Los herrajes se encuentran embolsados en uno de los cuatro laterales de protección del empaquetado, por lo que es necesario desenrollar la caja para acceder a ellos.

* Se recomienda el uso de destornillador eléctrico para el montaje del producto.

1

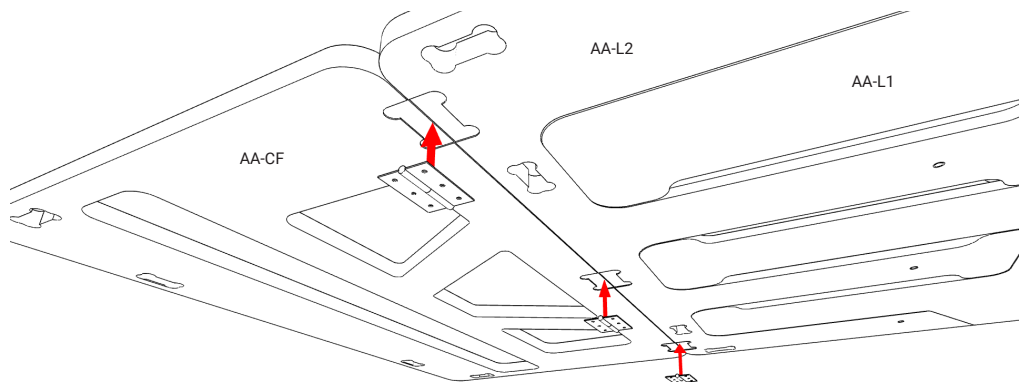

Para montar el mueble correctamente, **empieza por atornillar por separado las piezas AA-CF & AA-L2 y AA-CP & AA-L1.**

2

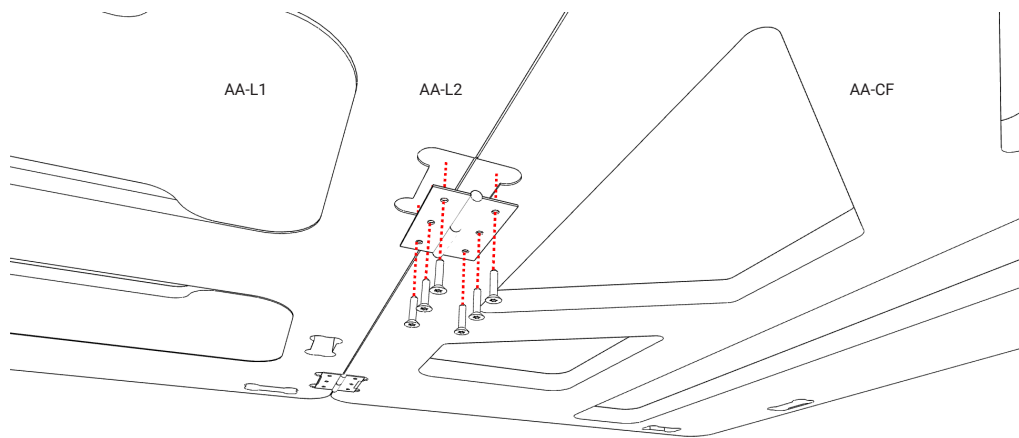

3

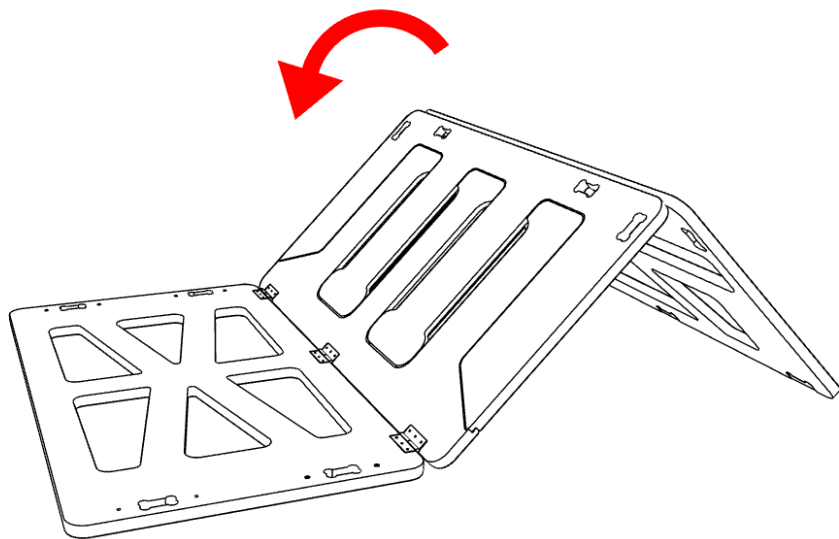

4

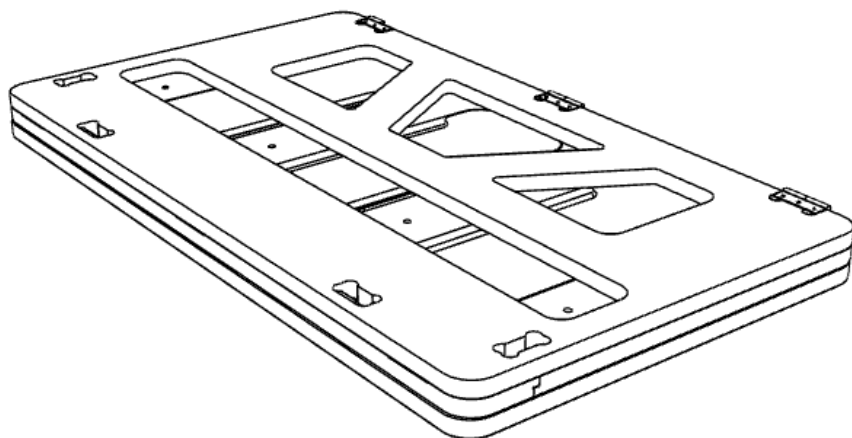

5

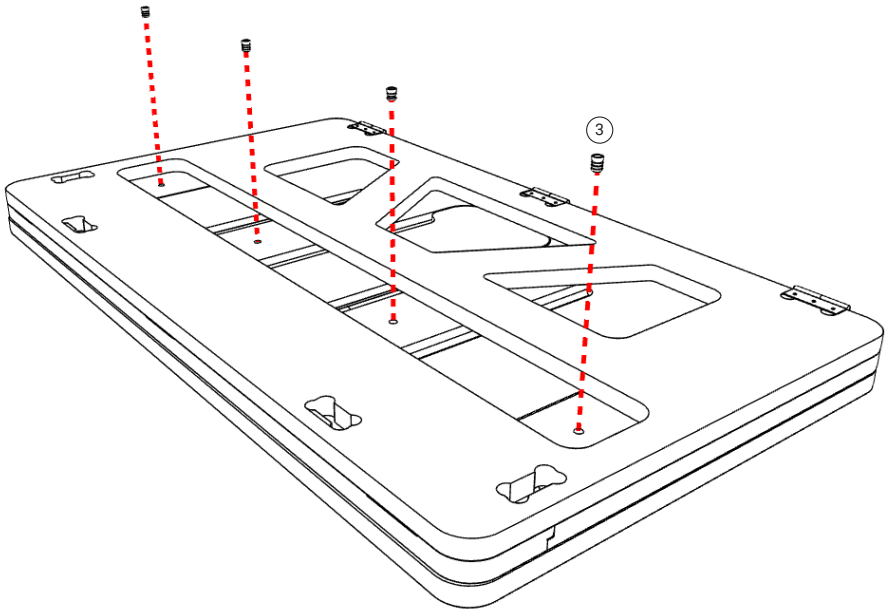

6

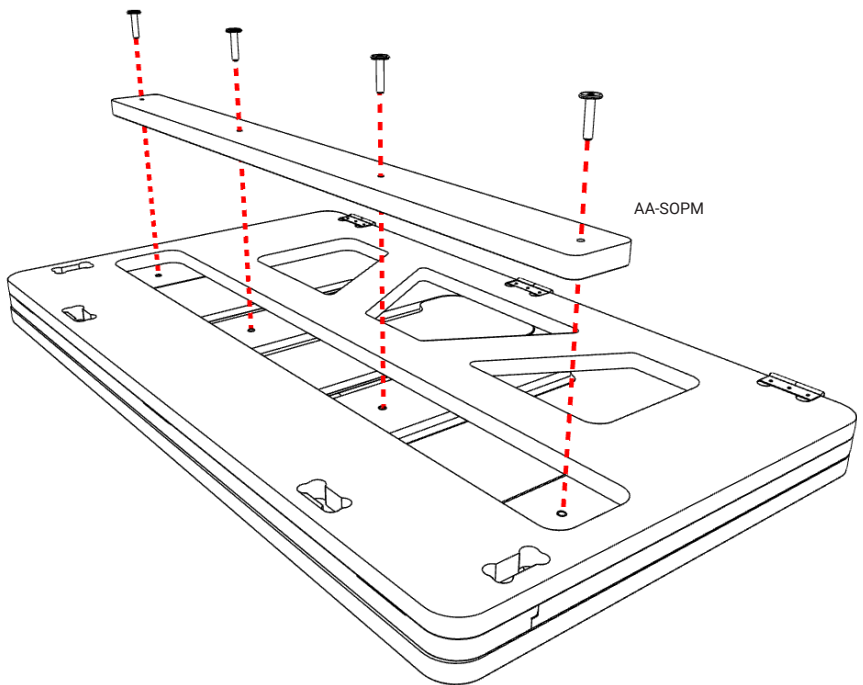

7

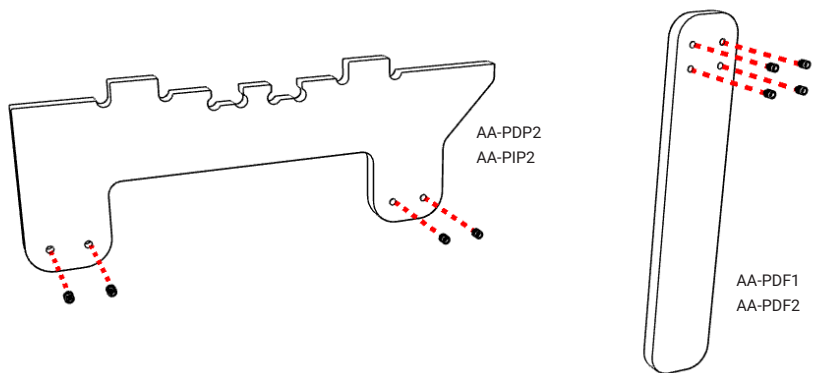

8

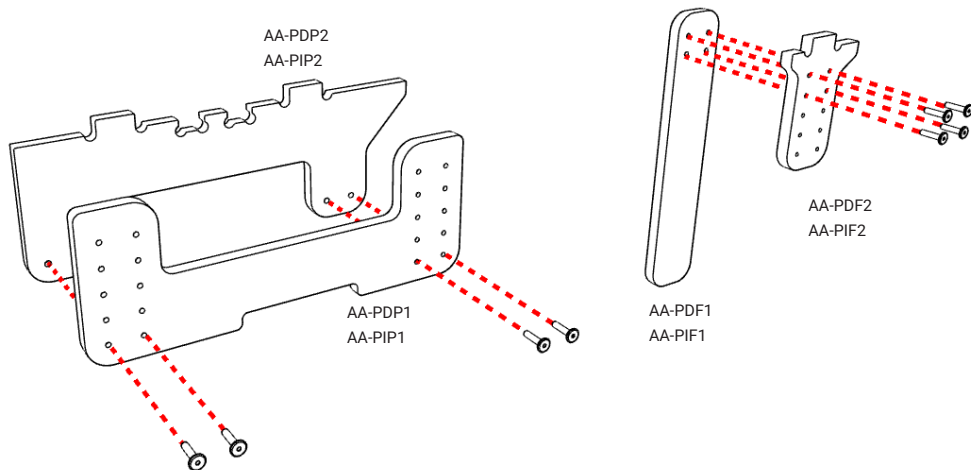

Para ajustar correctamente las piezas al desnivel de tu maletero, intruce la pieza AA-PDP1 en el coche y toma nota de la diferencia de altura con los asientos traseros plegados.

9

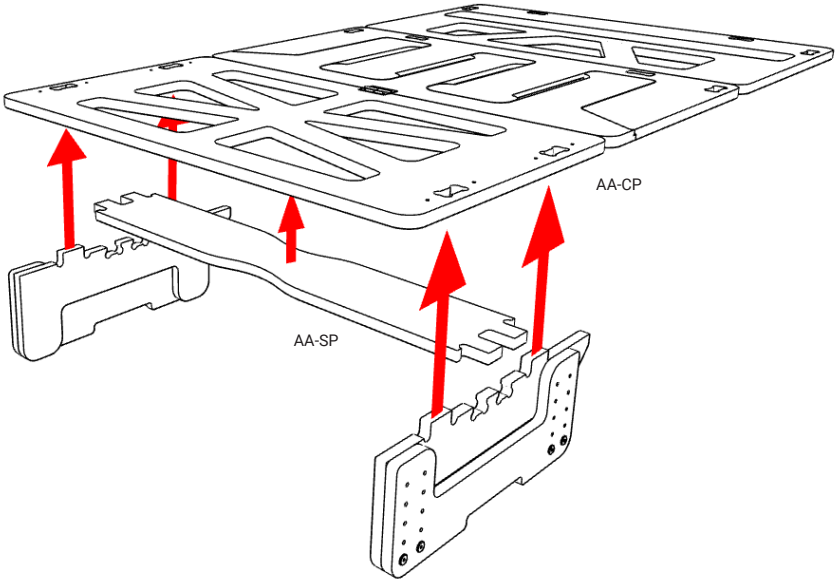

10

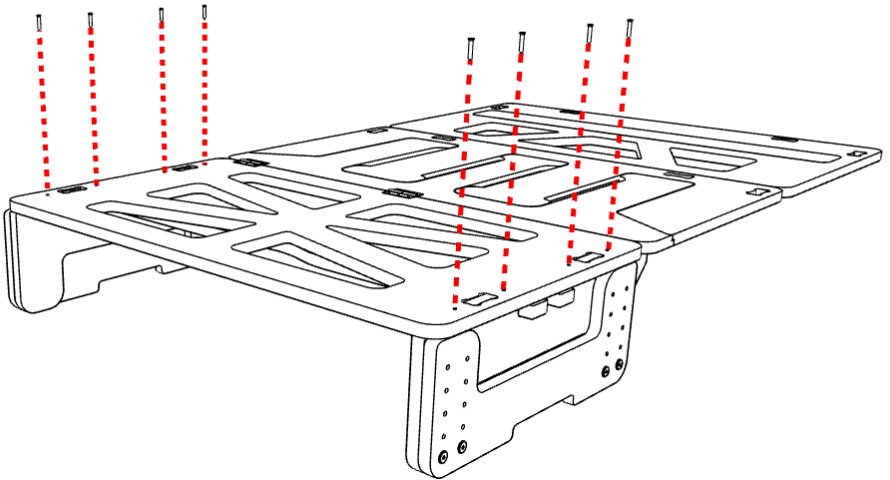

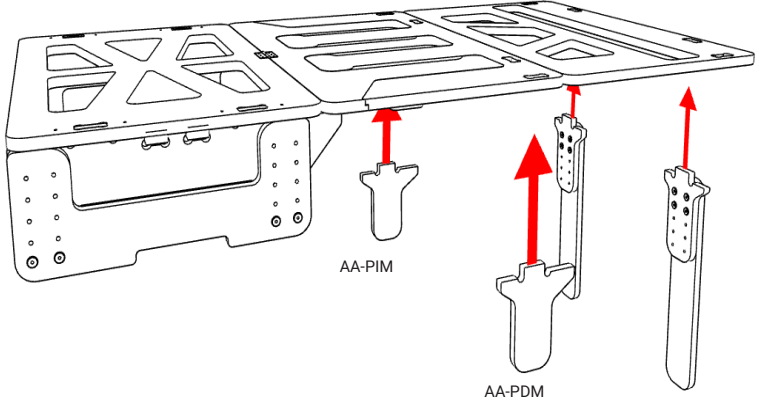

Para terminar, **despliega el módulo dentro del coche** con cuidado y coloca las piezas AA-PIM y AA-PDM y los módulos del paso 8 según las necesidades de tu vehículo.

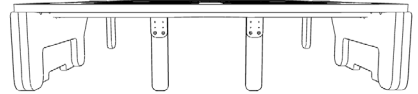
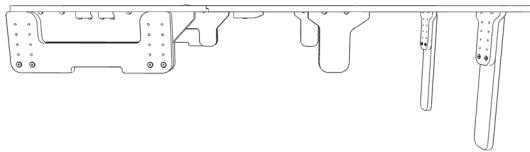
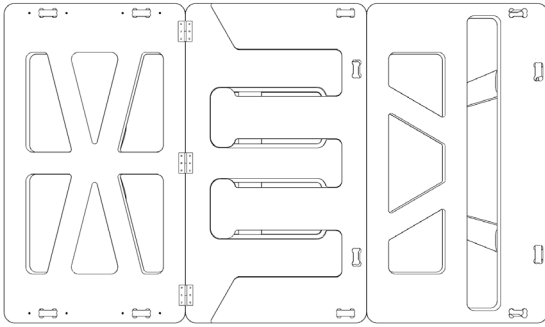

ADVERTENCIA

ES

Si un mueble vuelca, puede provocar daños de aplastamiento graves o fatales. Utiliza tornillos y tacos adecuados para tus muebles. En caso de duda, busca asesoramiento profesional. Lee y sigue cada paso de las instrucciones cuidadosamente.

- Para el montaje del mueble se requieren las herramientas expuestas en el manual
- Se recomienda realizar el montaje del producto con la ayuda de otra persona
- Para mayor precaución, se recomienda apoyar el objeto en una superficie textil (alfombra, moqueta...) durante su montaje
- Durante el proceso de montaje y tras finalizarlo, se debe apoyar el mueble cuidadosamente en una superficie plana
- Se debe tener precaución en todo momento ante una posible caída del mueble
- Para cualquier duda o consulta, le recomendamos que llame a nuestro servicio de atención al cliente

WARNING

EN

If a piece of furniture tips over, it can cause serious or fatal crushing damage. Use screws and plugs suitable for your furniture. If in doubt, seek professional advice. Read and follow each step of the instructions carefully.

- To assemble the furniture, the tools listed in the manual are required
- It is recommended to assemble the product with the help of another person
- For greater caution, it is recommended to rest the object on a textile surface (rug, carpet...) during assembly.
- During the assembly process and after completion, the furniture must be carefully supported on a flat surface
- Caution must be taken at all times against a possible fall of the furniture
- For any questions or queries, we recommend that you call our customer service

AVISO

PT

Se um móvel tombar, poderá causar danos graves ou fatais por esmagamento. Use parafusos e buchas adequados para seus móveis. Em caso de dúvida, procure aconselhamento profissional. Leia e siga cada etapa das instruções cuidadosamente.

- Para montar os móveis são necessárias as ferramentas listadas no manual
- Recomenda-se montar o produto com a ajuda de outra pessoa
- Para maior cautela, recomenda-se apoiar o objeto sobre uma superfície têxtil (tapete, carpete...) durante a montagem
- Durante o processo de montagem e após a finalização, os móveis devem ser cuidadosamente apoiados em uma superfície plana
- Deve-se ter sempre cuidado contra uma possível queda dos móveis
- Para qualquer dúvida ou consulta, recomendamos que você ligue para nosso atendimento ao cliente

